

# Thermit Weld Accessories

Thermit weld is also known as exothermic bonding, thermite welding (TW), and Thermit welding. There are many advantages of using exothermic weld. The most important one being that the process produces a molecular joint and not just a mechanical one in between the conductors. It is produced through a starting reactant which provides enough energy to activate the welding reaction. This takes place quickly and safely inside a graphite mould. The mould is designed specifically for a certain union depending on the elements to be welded and the joint type required. We guarantee all types of joints, not only copper cable unions but also to weld tapes, brass metallic pieces, stainless steel, steel ground rods covered with copper, etc. It is especially useful for joining dissimilar metals.

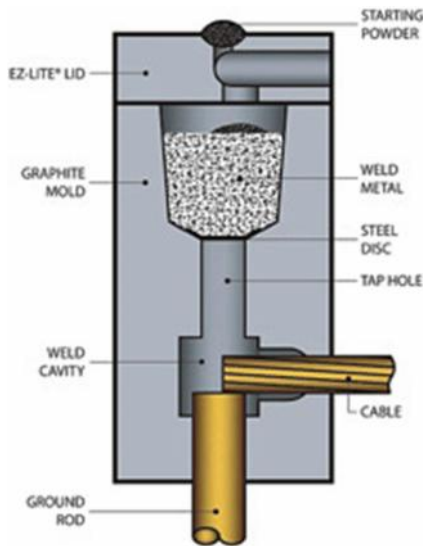

## Features of Thermit Weld:

- Superior electrical conductivity to the conductors themselves.
- Does not corrode, oxidize or degrade with time and is resistant to galvanic coupling.
- Able to withstand repeated electrical discharges.
- Never increases its resistance.
- Has greater mechanical and squeezing resistance than the conductors themselves.

## Exothermic Weld

Source: Wikipedia

Exothermic weld is a welding process for joining two electrical conductors that employs superheated copper alloy to permanently join the conductors. The process employs an exothermic reaction of a copper thermite composition to heat the copper, and requires no external source of heat or current. The chemical reaction that produces the heat is an alumina thermic reaction between aluminium powder and a metal oxide.

The reaction reaches very high temperatures, depending on the metal oxide used. The reactants are usually supplied in the form of powders, with the reaction triggered using a spark from a flint lighter. The activation energy for this reaction is very high however, and initiation requires either the use of a "booster" material such as powdered magnesium metal or a very hot flame source. The aluminium oxide slag that it produces is discarded.

When welding copper conductors, the process employs a semi-permanent graphite crucible mould, in which the molten copper, produced by the reaction, flows through the mould and over and around the conductors to be welded, forming an electrically conductive weld between them. When the copper cools, the mould is either broken off or left in place. Alternatively, hand-held graphite crucibles can be used. The advantages of these crucibles include portability, lower cost (because they can be reused), and flexibility, especially in field applications.

The weld formed has higher mechanical strength than other forms of weld, and excellent corrosion resistance. It is also highly stable when subject to repeated short-circuit pulses, and does not suffer from increased electrical resistance over the lifetime of the installation. However, the process is costly relative to other welding processes, requires a supply of replaceable moulds, suffers from a lack of repeatability, and can be impeded by wet conditions or bad weather (when performed outdoors).

Overview:

In exothermic weld, aluminium dust reduces the oxide of another metal, most commonly iron oxide, because aluminium is highly reactive. Iron(III) oxide is commonly used:



The products are aluminium oxide, free elemental iron, and a large amount of heat. The reactants are commonly powdered and mixed with a binder to keep the material solid and prevent separation. Commonly the reacting composition is 5 parts iron oxide red (rust) powder and 3 parts aluminium powder by weight, ignited at high temperatures. A strongly exothermic (heat-generating) reaction occurs that via reduction and oxidation produces a white hot mass of molten iron and a slag of refractory aluminium oxide. The molten iron is the actual welding material; the aluminium oxide is much less dense than the liquid iron and so floats to the top of the reaction, so the set-up for welding must take into account that the actual molten metal is at the bottom of the crucible and covered by floating slag.

Other metal oxides can be used, such as chromium oxide, to generate the given metal in its elemental form. Copper thermite, using copper oxide, is used for creating electric joints in a process called Cad welding:



**Thermite welding** is widely used to weld **railway rails**. The weld quality of chemically pure thermite is low due to the low heat penetration into the joining metals and the very low carbon and alloy content in the nearly pure molten iron. To obtain sound rail road welds, the ends of the rails being thermite welded are preheated with a torch to an orange heat, to ensure the molten steel is not chilled during the pour. Because the thermite reaction yields relatively pure iron, not the much stronger steel, some small pellets or rods of high-carbon alloying metal are included in the thermite mix; these alloying materials melt from the heat of the thermite reaction and mix into the weld metal. The alloying beads composition will vary, according to the rail alloy being welded.

Process

Typically, the ends of the rails are cleaned, aligned flat and true, and spaced apart 25 millimetres (0.98 in). This gap between rail ends for welding is to ensure consistent results in the pouring of the molten steel into the weld mould. In the event of a welding failure, the rail ends can be cropped to a 75 millimetres (3.0 in) gap, removing the melted and damaged rail ends, and a new weld attempted with a special mould and larger thermite charge. A two or three piece hardened sand mould is clamped around the rail ends, and a torch of suitable heat capacity is used to preheat the ends of the rail and the interior of the mould. The proper amount of thermite with alloying metal is placed in a refractory crucible, and when the rails have reached a sufficient temperature, the thermite is ignited and allowed to

react to completion (allowing time for any alloying metal to fully melt and mix, yielding the desired molten steel or alloy).

The reaction crucible is then tapped at the bottom. Modern crucibles have a self-tapping thimble in the pouring nozzle. The molten steel flows into the mould, fusing with the rail ends and forming the weld. The slag, being lighter than the steel flows last from the crucible and overflows the mould into a steel catch basin, to be disposed of after cooling. The entire setup is allowed to cool. The mould is removed and the weld is cleaned by hot chiselling and grinding to produce a smooth joint. Typical time from start of the work until a train can run over the rail is approximately 45 minutes to more than an hour, depending on the rail size and ambient temperature. In any case, the rail steel must be cooled to less than 370 °C (698 °F) before it can sustain the weight of rail locomotives.

When a thermite process is used for track signals – the bonding of wires to the rails with a copper alloy, a graphite mould is used. The graphite mould is reusable many times, because the copper alloy is not as hot as the steel alloys used in rail welding. In signal bonding, the volume of molten copper is quite small, approximately 2 cubic centimetres (0.12 cu in) and the mould is lightly clamped to the side of the rail, also holding a signal wire in place. In rail welding, the weld charge can weigh up to 13 kilograms (29 lb). The hardened sand mould is heavy and bulky, must be securely clamped in a very specific position and then subjected to intense heat for several minutes before firing the charge. When rail is welded into long strings, the longitudinal expansion and contraction of steel must be taken into account. British practice is to use a sliding joint of some sort, to allow this movement. American practice is very often a straightforward physical restraint of the rail. The rail is pre stressed, or considered "stress neutral" at some particular ambient temperature. This "neutral" temperature will vary according to local climate conditions, taking into account lowest winter and warmest summer temperatures. The rail is physically secured to the ties or sleepers with rail anchors, or anti-creepers. If the track ballast is good and clean and the ties are in good condition, and the track geometry is good, then the welded rail will withstand ambient temperature swings normal to the region.

#### Remote welding

Remote Thermit weld is a type of exothermic weld process for joining two electrical conductors from a distance. The process reduces the inherent risks associated with exothermic welding and is used in installations that require a welding operator to permanently join conductors from a safe distance of the superheated copper alloy.

The process incorporates either igniters for use with standard graphite moulds or a consumable sealed drop in weld metal cartridge, semi-permanent graphite crucible mould, and an ignition source that tethers to the cartridge with a cable that provides the safe remote ignition.

[Amiable Impex](#) supply Thermit Welding Accessories all over India mainly at Ahmadabad, Pune, Delhi, Mumbai, Bangalore, Chennai, Kolkata, Surat, Pune, Lucknow, Kanpur, Nagpur, Indore, Bhopal, Vadodara(Baroda) etc.

For more details or any queries in terms for Thermit Welding Accessories please visit us at <http://www.amiableimpex.com> or mail us at [info@amiableimpex.com](mailto:info@amiableimpex.com)

### Our Other products in Exothermic Welding Powder / Thermite Weld

S.no	Table Of Content
1)	<a href="#">Exothermic Welding Powder</a>
2)	<a href="#">Thermite Welding Powder</a>
3)	<a href="#">Thermit Weld</a>
4)	<a href="#">Exothermic / Thermite Accessories</a>

Regd. Office -

**AMIABLE IMPEX.**

101/A, Surya Darshan, Pai Nagar,  
Borivali(W), Mumbai – 400092. **India.**  
Phone: 022-28933996 / 022-28957101  
Fax: 022-28957102



**AMIABLE IMPEX**

Plot No.495, Rohitvas,  
Motapondha, Vapi-396191  
Gujarat,India.

Contact Person -

**MAULIK SHAH**

E-mail: [maulik@amiableimpex.com](mailto:maulik@amiableimpex.com)  
Mob :+ 91- 9594899995

**UJJWAL SHAH**

E-mail: [ujjwal@amiableimpex.com](mailto:ujjwal@amiableimpex.com)  
Tel :+ 91- 22-28933996



**Website: [www.amiableimpex.com](http://www.amiableimpex.com)**